

NAME

**CHICK FEEDER 1 KG**

REFERENCE

**11215**

**PRODUCT FEATURES**

MATERIAL

POLYPROPYLENE

COLOR

GREEN LEMON - WHITE

WEIGHT

0,161 kg

CLOSURE TYPE

SCREW CLOSURE

ACCESSORIES



SKETCH

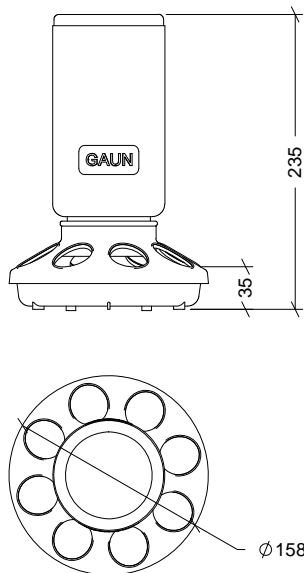

SECTIONAL

Nº	DESCRIPTION
1	BOTTLE
2	ANTI-WASTE RING
3	BASE

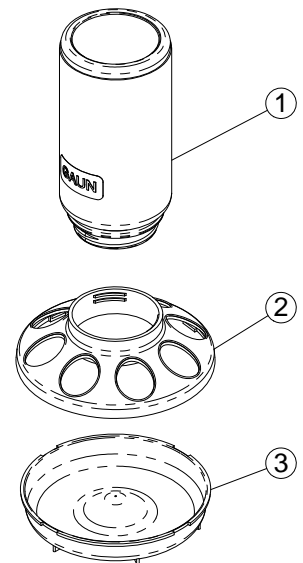

**PACKAGING FEATURES**

PACKAGING TYPE

BOX

UNITS/PACKAGING

10 Units

PACKING DIMENSIONS

555x305x280 mm

PACKING WEIGHT

2,100 kg

PACKING VOLUME

0,047 m<sup>3</sup>

EUROPALLET

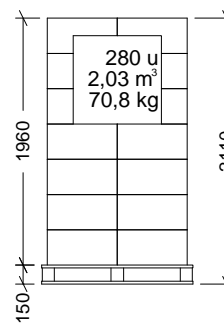

AMERICAN PALLET

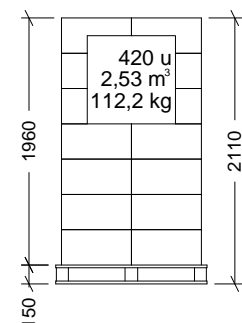

**EUROPALLET WEIGHT: 12 kg**

**AMERICAN PALLET WEIGHT: 24 kg**

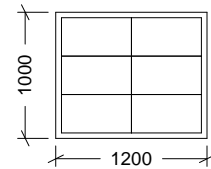
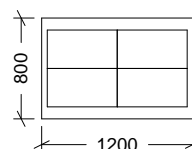

Dimensions in mm